



# Upgrading the performance of district heating networks

Best practice examples on upgrading  
projects

Authors: The corresponding authors are named as contact person at the end of each described project.

Editor: Tobias Roth  
AGFW Projekt GmbH  
Germany

Reviewers: Sebastian Grimm  
AGFW Projekt GmbH  
Germany

Dominik Rutz  
WIP Renewable Energies  
Germany

Contact: AGFW Projekt GmbH  
Sebastian Grimm  
s.grimm@agfw.de  
Tel: +49 69 6304 200  
Stresemannalle 30  
60596 Frankfurt/Main  
[www.agfw.de](http://www.agfw.de)

Website: Upgrade DH project website: [www.upgrade-dh.eu](http://www.upgrade-dh.eu)

Cover: AGFW Projekt GmbH

Project relation: WP2, Task 2.1, Deliverable 2.1

Copyright: All rights reserved. No part of this book may be reproduced in any form or by any means, in order to be used for commercial purposes, without permission in writing from the publisher.

Disclaimer: This project has received funding from the European Union's Horizon 2020 research and innovation programme under grant agreement No 785014. The sole responsibility for the content of this report lies with the authors. It does not necessarily reflect the opinion of the European Union nor of the Executive Agency for Small and Medium-sized Enterprises (EASME). Neither the EASME nor the European Commission are responsible for any use that may be made of the information contained therein.



This project has received funding from the European Union's Horizon 2020 research and innovation programme under grant agreement No 785014.

## The Upgrade DH Project

The overall objective of the Upgrade DH project is to improve the performance of district heating (DH) networks in Europe by supporting selected demonstration cases for upgrading, which can be replicated in Europe.

The Upgrade DH project supports the upgrading and retrofitting process of DH systems in different climate regions of Europe, covering various countries: Bosnia-Herzegovina, Denmark, Croatia, Germany, Italy, Lithuania, Poland, and The Netherlands. In each of the target countries (Figure 1), the upgrading process will be initiated at concrete DH systems of the so-called Upgrade DH demonstration cases (demo cases). The gained knowledge and experiences will be further replicated to other European countries and DH systems (replication cases) in order to leverage the impact.

Core activities of the Upgrade DH project include the collection of the best upgrading measures and tools, the support of the upgrading process for selected district heating networks, the organisation of capacity building measures about DH upgrading, financing and business models, as well as the development of national and regional action plans.

In addition, an image raising campaign for modern DH networks will be carried out in the Upgrade DH project. The outcome will be the initiation of district heating upgrading process in the above-mentioned target countries and beyond.

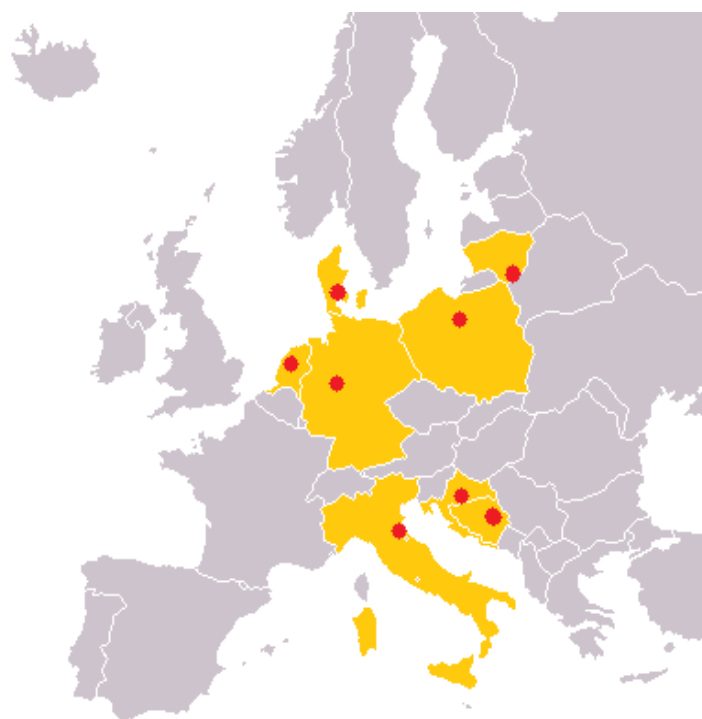

**Figure 1: Upgrade DH target countries and demo cases**

**Project Consortium and National Contact Points:**

**WIP Renewable Energies**, project coordinator, Germany

Dominik Rutz [Dominik.Rutz@wip-munich.de]

[www.wip-munich.de](http://www.wip-munich.de)



**Steinbeis Research Institute for Solar and Sustainable Thermal Energy Systems**, Germany

Thomas Pauschinger [Pauschinger@solites.de]

[www.solites.de](http://www.solites.de)



**Lithuanian District Heating Association**

(Lietuvos Šilumos Tiekėjų Asociacija), Lithuania

Audrone Nakrosiene [audronenakrosiene@gmail.com]

[www.lsta.lt](http://www.lsta.lt)



**Salcininku Šilumos Tinklai**, Lithuania

Elena Pumputienė [elena.pumputiene@sstinklai.lt]

[www.sstinklai.lt](http://www.sstinklai.lt)



**JP Elektroprivreda BiH d.d.-Sarajevo**, Bosnia-Herzegovina

Anes Kazagic [a.kazagic@elektroprivreda.ba]

[www.elektroprivreda.ba](http://www.elektroprivreda.ba)



**AGFW - Projektgesellschaft für Rationalisierung, Information und Standardisierung mbH**, Germany

Sebastian Grimm [grimm@agfw.de]

[www.agfw.de](http://www.agfw.de)



**University of Zagreb, Faculty of Mechanical Engineering and Naval Architecture**, Croatia

Tomislav Pukšec [tomislav.puksec@fsb.hr]

[www.fsb.unizg.hr](http://www.fsb.unizg.hr)



**COWI A/S**, Denmark

Reto Michael Hummelshøj [rmh@cowi.com]

[www.cowi.com](http://www.cowi.com)



**OPTIT Srl**, Italy

Matteo Pozzi [matteo.pozzi@optit.net]

[www.optit.net](http://www.optit.net)



**Gruppo Hera**, Italy

Simone Rossi: [simone.rossi@gruppohera.it]

[www.gruppohera.it](http://www.gruppohera.it)



**Euroheat & Power – EHP**, Belgium

Alessandro Provaggi [ap@euroheat.org]

[www.euroheat.org](http://www.euroheat.org)

# Contents

<b>The Upgrade DH Project</b>	<b>3</b>
<b>1. Integration of Thermal Storage in Existing DH System in the City of Zagreb</b>	<b>6</b>
<b>2. Optimisation of Pumping Operations in the DH System of Ferrara</b>	<b>9</b>
<b>3. Integration of Tube Collectors for Solar District Heating</b>	<b>12</b>
<b>4. Biomass Fired Boiler House at the Plant Salcininkai</b>	<b>15</b>
<b>5. Renovation of the DH System in Akmenė</b>	<b>18</b>
<b>6. Green Energy Park Livno</b>	<b>21</b>
<b>7. Replacement of Fossil Fuels in the DH Sector of Lithuania</b>	<b>24</b>
<b>8. Integration of Solar Thermal Energy in an Existing DH System</b>	<b>27</b>
<b>9. Energy Renovation with Focus on Low-Temperature DH in Albertslund</b>	<b>30</b>
<b>10. Interconnection of Two Separated DH Networks in Italy</b>	<b>33</b>



# 1. Integration of Thermal Storage in Existing DH System in the City of Zagreb

Implementation of the Buffer Storage Tank in the Existing District Heating System of the City of Zagreb

Zagreb, Croatia

Technical  
Description

Year of the Retrofitting Project: 2015

## Project Summary

The district heating system in Zagreb is the largest in Croatia, with 1,420 MW of thermal power installed that supply 30% of the households in Zagreb. The upgraded district heating system is owned by TE-TO Zagreb. TE-TO Zagreb operates cogeneration plants, which provide hot water for heating, as well as steam for industrial uses.

In order to increase the efficiency and to lower the costs of the DH system in Zagreb, a buffer storage tank has been installed at the end of 2015. This project presents the first storage tank of such size in Croatia and it already provides significant benefits for the DH utility.

With the integrated storage, it was possible to reduce the operating time and fuel consumption of peak-load boilers, and at the same time to increase the operating time of the cogeneration plants. This decreased the annual CO<sub>2</sub>-emissions. In addition, due to the installation of the storage system, further invest costs for a new peak-load boiler were avoided.



Figure 2 Thermal power plant of Zagreb with the new, integrated thermal storage (blue),

source: [www.hkis.hr](http://www.hkis.hr)

## Project's Characteristics

Retrofitting Types	Targets of the Retrofitting Measure	Effected Areas
Technical, Economical	Efficiency Gains, Economic Improvement	Power Plants

### Motivation behind the Project

The project's motivation was, to achieve **multiple benefits** with a **clear effort** in form of invest costs. The implemented measure was intended to prevent the installation of an additional peak-load boiler. Most other benefits were caused by the provided flexibility in heat production. Storages enable to **flatten peak-loads** (an ideal and quantitative load-profile is illustrated with the graph below) and in the case of cogeneration plants to give flexibility between the production of heat and electricity.

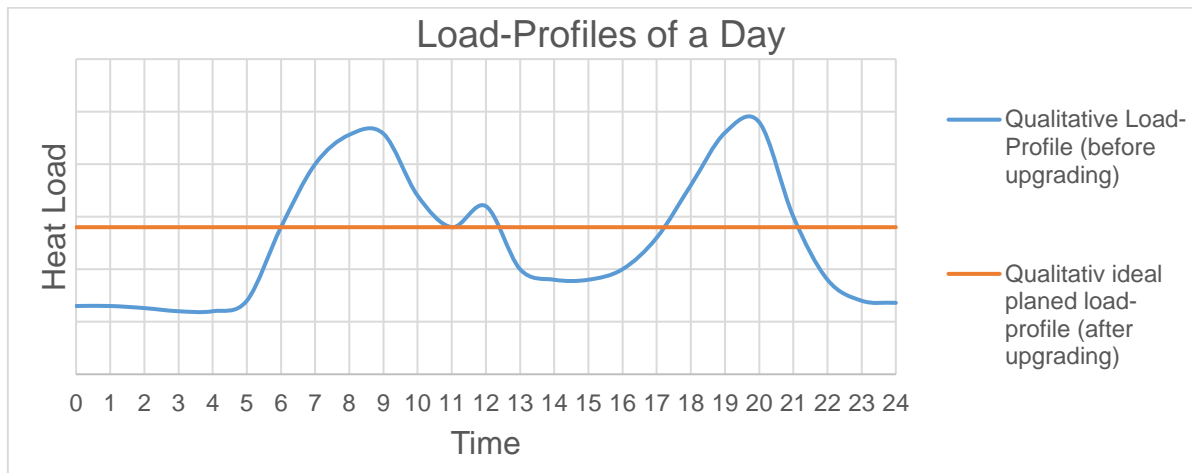

**Figure 3 Effect of thermal storages on load-profiles**

### Financial Effort versus Benefits

Financial Effort		Benefits
Entire investment costs for the retrofitting measure were around 7,000,000 €	<b>VERSUS</b>	Economic benefit of 600,000 € per year
		Decreased fuel consumption by approx. 934 t per year
		Decreased CO <sub>2</sub> -emissions by 2,978 t per year
		Electrical energy savings around 220 MWh per year
		Prevent the installation of an additional new peak-load boiler

### Outlook and Importance of the Technology

The results of the buffer tank implementation in TE-TO Zagreb showed a number of benefits for the system from both, the technical and the economic side. This project represents a good role model for other large district heating systems in Croatia. Finally, new district heating systems in Croatia already **replicated this concept**, for example in the small renewable district heating system of Pokupsko.

### Technical Data of the Installed Heat Storage

- The installed heat storage is classified as a daily, cylindrical thermal storage and non-pressurized water tank.
- Storage volume: 21,500 m<sup>3</sup>
- Heat storage capacity: 750 MWh
- Minimum charging temperature 98 °C
- Maximum returning water temperature: 58 °C
- Loading capacity: 150 MW

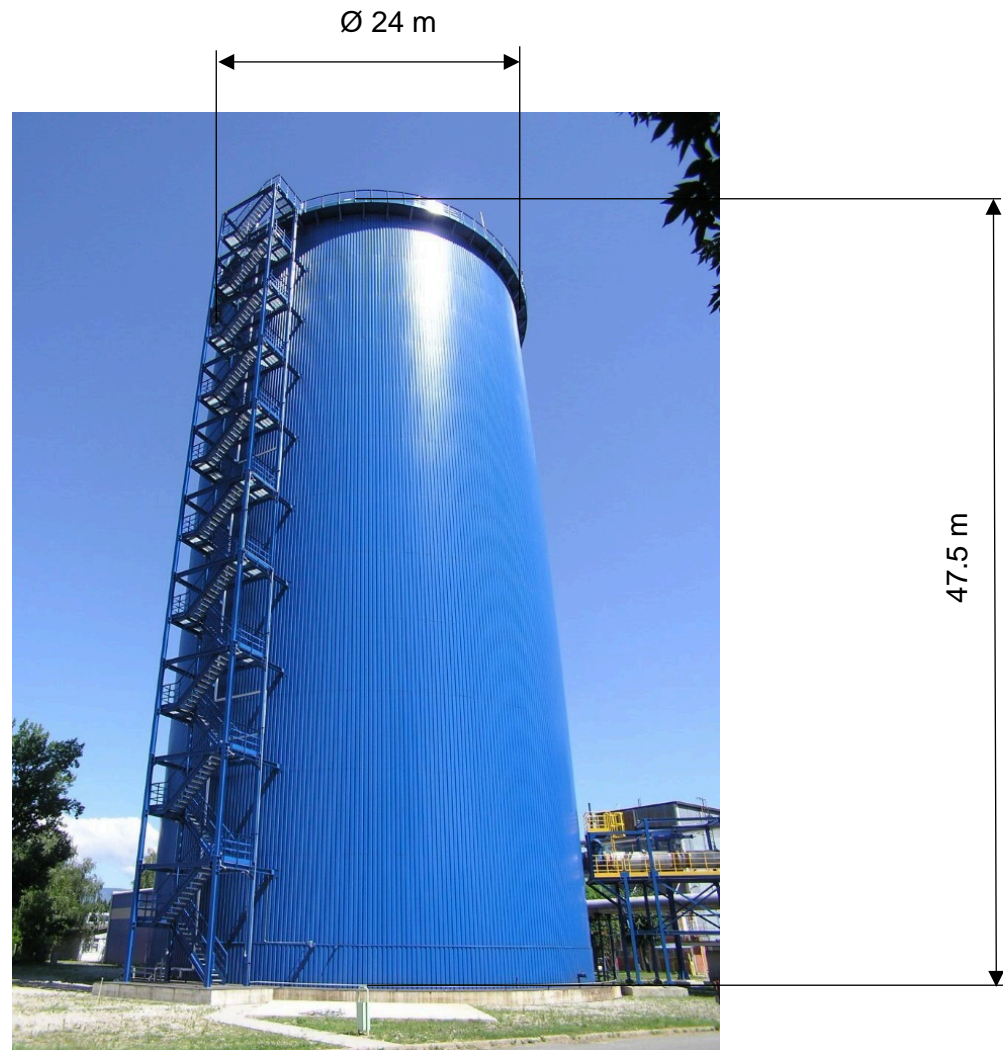

Figure 4 Thermal Storage of the district heating system in Zagreb,

source: [www.pogledaj.to](http://www.pogledaj.to)

For more information follow the reference:

[Presentation of the Storage's Characteristics](#)

Or get in contact with: Borna Doracic  
University of Zagreb, Faculty of Mechanical Engineering and  
Naval Architecture  
[borna.doracic@fsb.hr](mailto:borna.doracic@fsb.hr)



## 2. Optimisation of Pumping Operations in the DH System of Ferrara

Ferrara, Italy

Technical Description

Period of the Retrofitting Project: 2016 – 2017

### Project Summary

The district heating system of the municipality of Ferrara supplies heat for space heating and domestic hot water in a rather large area of the city. The network is the result of 28 years of expansion since its start in 1990 and reaches a total route length of 80 km. The aim of the upgrading process was reducing the network supply pressure, whenever this was excessive, yet assuring that the customers were served properly. In order to achieve this goal, many critical points in the networks in Hera were equipped with SCADA (Supervisory Control and Data Acquisition) systems, so that differential pressure and supply temperature started to be monitored.

Hera implemented the same pressure control strategy in the district heating network of Imola (Italy), which is characterized by a similar network structure as Ferrara. The leverage of the presented measure is even higher if the system’s pressure drop and the distance of the district heating network are high.

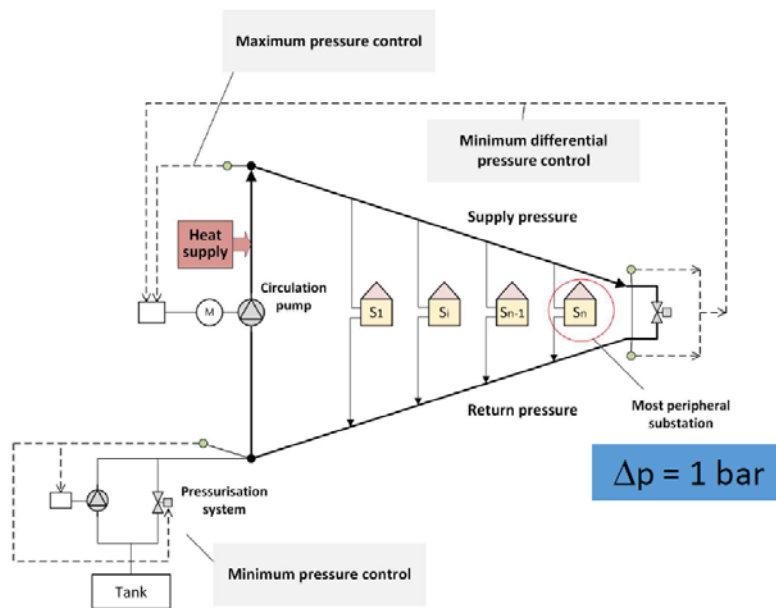

Figure 5 New pressure management system after the implementation of the SCADA system

### Project’s Characteristics

Retrofitting Types	Target of the Retrofitting Measure	Effected Area
Technical, Economical	Efficiency Gains	Primary Grid

### Characteristics of the District Heating System in Ferrara

- The distribution network has a total length of 80 km.
- The system has a supplying temperature of 90 °C and the returning temperature is varying between 55 °C and 60 °C.
- More than 600 substations are connected to the district heating system and supply a total area of 5.75 million m<sup>3</sup>.
- The connected consumers are residential as well as public and commercial buildings.
- With a two-tank storage system, the network is separated into the supplying-side and consuming-side.

### Characteristics of the Production-Side

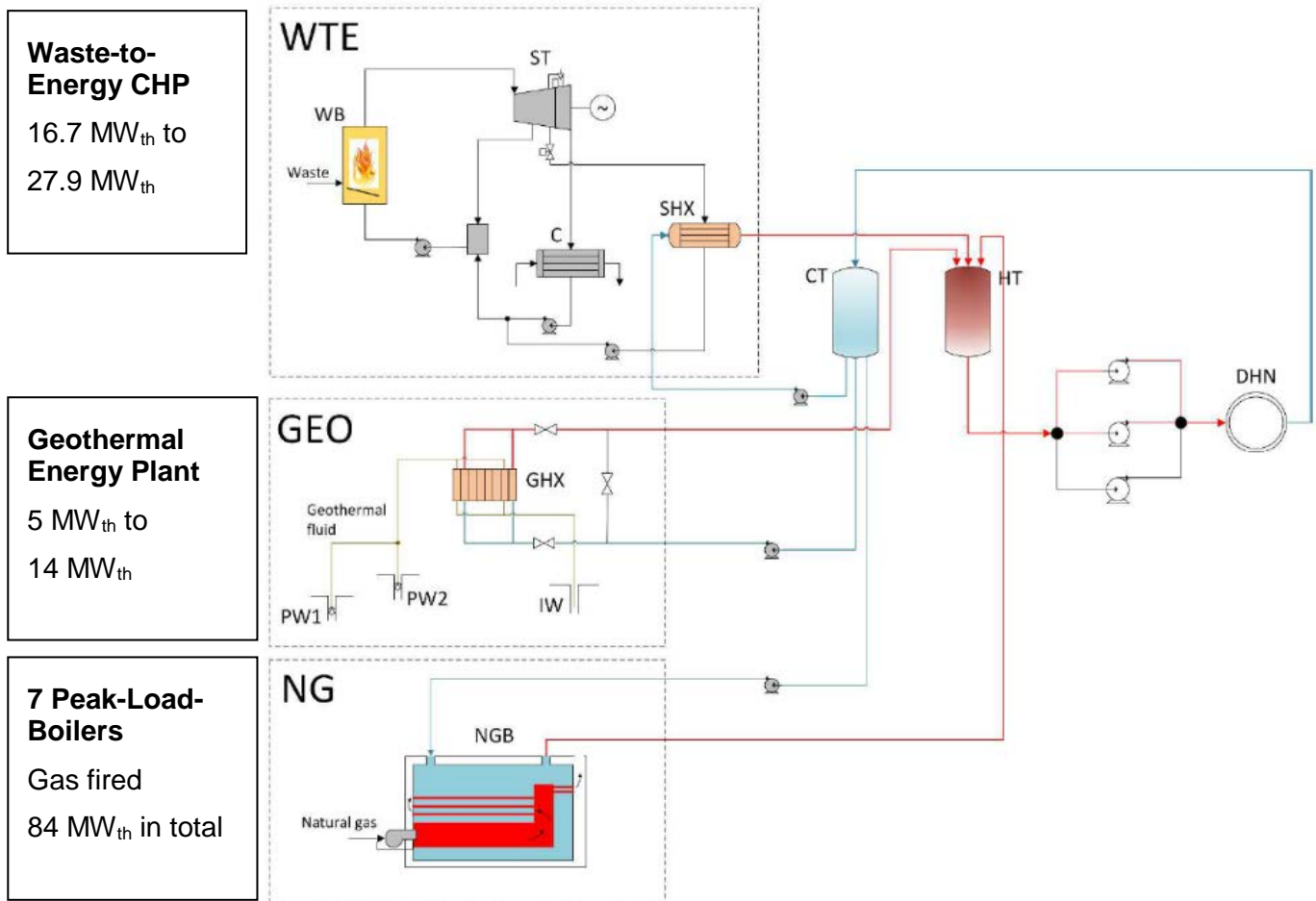

**Figure 6 Scheme of the different producer technologies**

### Regulatory Strategy before the Upgrading Process

Over the years, Hera's employees and system operators developed a heuristic table yielding the target supply pressure, depending on outdoor temperature and time of the day, where higher pressures corresponded to a higher heat demand. This heuristic table was used to adjust the system's parameter and enables a secure heat supply for the consumers.

### Regulatory Strategy after the Upgrading Process

After the technological infrastructure had been set up, in terms of connecting the **SCADA** system to the network, a **new regulation strategy** for the pumping station was implemented. In essence, the VSD (Variable Speed Driver) pumps operated through **a control logic** that determined the proper rotational speed (thus flow rate) depending on the measurement of the pressure drop at the most critical user, so that in this site the pressure drop could approach as much as possible the minimum value of 1 bar.

### Benefit of the Retrofitting Measure

The supply pressure profiles were analysed, comparing the years 2015 and 2017. It showed that supply pressures managed to be reduced up to 2-3 bar, so that the mechanical losses associated with the throttling process (i.e. mainly the control valves) in all substations and, consequently, the power absorbed by the circulation pumps were markedly reduced.

Moreover, the beneficial effect deriving from the reduction of the minimum pressure difference in the most peripheral substation had positive repercussions on the entire grid. The annual electrical demand of the pumping station in the winter period had reached 1,400 MWh in 2015. By assuming an annual average **electrical saving of 30%**, the estimated annual electrical consumption after the energy conservation strategy is approximately 1,000 MWh, which corresponds to an **energy saving of 75 TOE** (tonnes of oil equivalent) per year.

For more information follow the reference:

Manente G., Lazzaretto A., Molinari I., Bronzini F., Ferraresi F., (2017) Energy conservation in a geothermal and waste-to-energy district heating system in northern Italy – ECOS 2018 the 31<sup>st</sup> international conference on efficiency, cost, optimization, simulation and environmental impact of energy systems June 17-22, 2018, Guimarães, Portugal.  
[www.ecos2018.org](http://www.ecos2018.org)

Or get in contact with:

Federico Bronzini  
Hera Spa  
federico.bronzini@gruppohera.it  
Tel: +39 3484062354

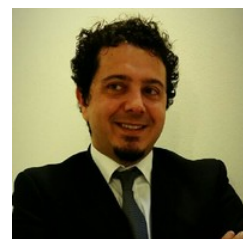

### 3. Integration of Tube Collectors for Solar District Heating

Senftenberg, Germany

Year of the Retrofitting Project: 2016



Project Summary

In the region of Senftenberg with a total population of about 25.000 people, 10.000 households are connected to the regional district heating system. In the past, the heat demand of this district heating system was covered by ignite-fired power plants. Furthermore, thanks to its large ignite deposit Senftenberg was the “Energy-Center” for the state of Brandenburg.

But since 2006 Senftenberg is one of the pioneers in suitable supply of district heating systems in Germany with integrating renewables to their systems. In 2006, the (until then) biggest biogas-fired plant was installed. And ten years later in 2016 the biggest solar thermal plant was installed in Senftenberg either. Due to a good planning, the installation period for the solar thermal plant from the ground-breaking ceremony to first operating tests took only seven month.

The previous examination of the solar thermal plant which includes diverse evaluation of solar radiation and even later solar energy earnings lead to a very detailed and applicable estimation of the plant. The later measured data verified this estimations and even though exceeded them. Within just eight weeks the solar earnings reached 25 % of the expected annual earnings.



Figure 7 Collector field of Senftenberg



Figure 8 Installed tube collectors

Project’s Characteristics

Retrofitting Type	Targets of the Retrofitting Measure	Effected Areas
Technical	Primary Energy Savings, Share of Renewables, Displacement of Fossil Fuels	Primary Grid, Power Plant

District Heating System Senftenberg	Solar Thermal Plant Senftenberg
Annual heat demand 100 GWh	Annual heat production 4 GWh
Minimum heat load 3.8 MW	Peak heat capacity 4.6 MW
More than 33 km in length	8,300 m <sup>2</sup> collector field
More than 2000 m <sup>3</sup> of district heating water	consisting of 1,680 tube collectors

### Specific Characteristics of the Solar Thermal Plant

The solar thermal plant of Senftenberg is the largest solar plant in Germany.

The solar thermal plant is able to cover the heat demand alone in the month of July and August. Even the plant produces up to 20% excess heat in this time, the integration of an additional thermal storage was not necessary. The network with its 2000 m<sup>3</sup> of water is able to absorb the excess heat with an increase of the supplying temperature.

The plant's system is an "AquaSystem" which uses water as heat medium without the admixture of Glycol. This allows to use a smaller pipe diameter with equal conditions of heating flow and temperature level. An additional benefit of using water is the simple handling for environmental aspects like water protection areas. The protection against frost in the month of winter is ensured by using about 2 % percentage of solar gain for active frost-protection.

Even common solar thermal district heating system consists of plane collectors, the solar plant in Senftenberg is equipped with vacuum tube collectors. The main benefit of this technology is a higher solar earning with the same available area.

The plant was installed between two network arms two create a pipeline-ring. This allows the plant to operate in two different modes, depending on the available capacity.

1. Feeding in the supplying pipeline, in two directions
2. Increasing the temperature of the return flow

Furthermore an installed adjustable bypass-pipeline at the power plant allows it to bypass the plant in terms of covering the heat demand only with solar energy.

By integrating a diaphragm type expansion tank the plant is protected against negative consequence caused by stagnation.

Based on different simulations and calculation of the solar radiation on spot and the solar plant, *Ritter Solar XL* as producer of the solar plant was able to guarantee annual solar earnings of 4 GWh.



## Operating Modes

### 1. Feeding in the supplying pipe-line

The figure on the right represents the hydraulic scheme if the solar thermal plant is feeding directly in the supplying pipeline. Due to the pipeline ring of two networks this can happen in two opposite directions. The hydraulic separator allows constant temperatures for the collectors as well as for the heat exchanger. The heat exchanger is needed for decoupling the two water cycles with different temperature levels and different physical and chemical requirements for the water.

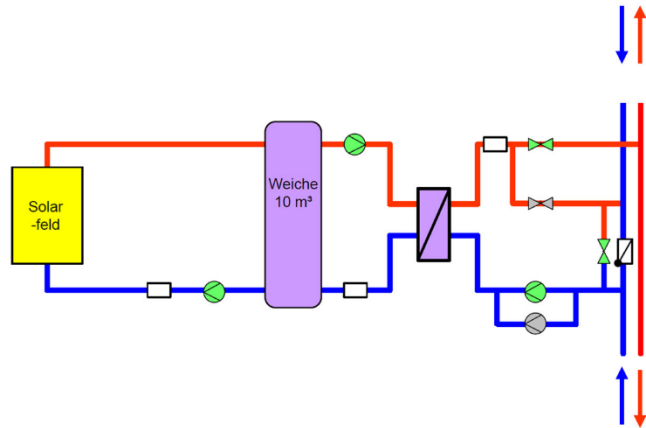

Figure 9 Feeding in the supplying pipeline

### 2. Increasing the temperature of the return flow

For the feasibility of increasing the temperature of the return flow (hydraulic scheme on the right), only about 10 % of the heat capacity is required, compared to the first operation mode.

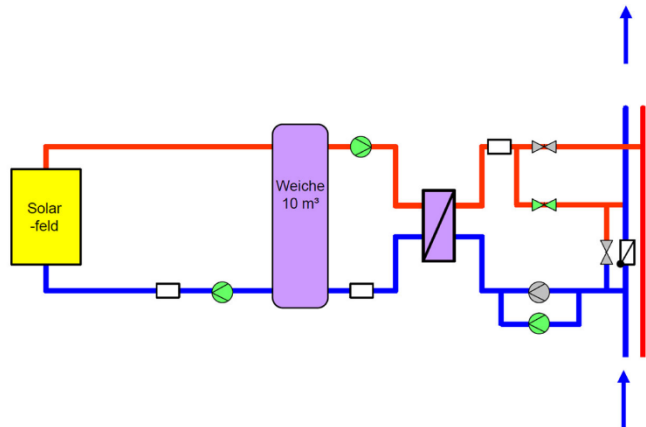

Figure 10 Increasing the temperature of the return flow

## Solar Earnings

The analysis on two representative days showed a good performance of the solar plant.

On a good day with nearly ideal condition the plant reach a cumulated feed-in of 27 MWh shared over eleven hours. Even on a bad day with unfavourable conditions the plant was approximately eight hours in operation and reached a feed-in of 8 MWh.

For more information  
get in contact with:

Sebastian Grimm  
AGFW Projekt GmbH  
Research and Development  
Tel: +49 69 6304-200  
Fax: +49 69 6304-455  
s.grimm@agfw.de



## 4. Biomass Fired Boiler House at the Plant Salcininkai

Salcininkai, Lithuania

Year of the Retrofitting Project: 2015

Technical and  
Economic  
Description

### Project Summary:

Salcininku silumos tinklai, Ltd is the operator of the district heating system in Salcininkai and is in charge of providing heat energy supply to households, state authorities and businesses in the city and within the districts. The annual heat demand of approximately 30 GWh is transmitted through a 18.7 km distribution network to about 2,200 consumers.

The retrofitting measure were applied to the power plant in the city of Salcininkai, in which problems with high costs of heat generation, depending on fossil fuel were identified. The district heating system was upgrade by installing a 5 MW wood chips fired boiler with 1.25 MW condensing economizer. Besides the economic aspects, the decision for the upgrading project was made for local and regional reasons.



Figure 11 Old fossil fuel fired boiler

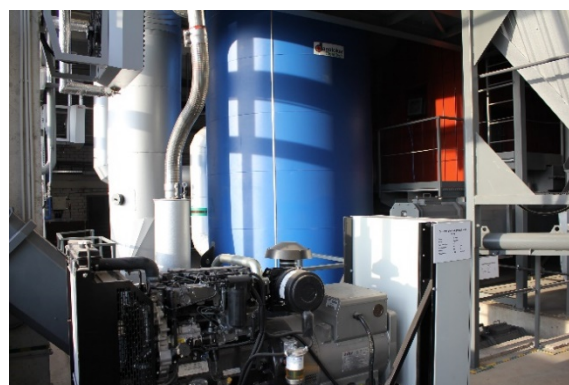

Figure 12 New biomass fired boiler

### Project's Characteristics

Retrofitting Types	Targets of the Retrofitting Measure	Effected Areas
Technical, Economic	Share of Renewables, Economic Improvement	Power Plants

### Motivation behind the Project

Wood chips are a nationally available heat source that can be provided by national and regional businesses. This reduces the dependency on fossil fuel and improves the security of heat supply. Furthermore, it supports national businesses and promotes the national economy. Another motivation of the retrofitting measure was to decrease carbon dioxide emissions and to contribute towards an environmentally friendly heat production. Finally, the motivation was to lower the heating price for consumers by reducing the costs for heat production at the same time.

### Advantages of Using Biomass as Energy Source

Biomass can provide an economical and environmentally friendly source of heat. It can reduce CO<sub>2</sub> emissions as it is renewable. Due to the local availability, utilities are independent from international, or in this case even from external, suppliers. This also increases the security of supply for the consumers. Furthermore, compared to fossil fuels, biomass has usually more stable and as well lower costs.



Figure 13 Feed-in system of a woodchip boiler

The **main benefit** reached by the retrofitting DH system was the **reduction of costs for heat generation** by replacing expensive natural gas with woodchips. Therefore, the **heating price for the customers was reduced by 12 %**.

## New equipment

Within the presented retrofitting project, **different individual measures** were involved. This includes the installation of **new equipment or the replacement of old equipment**. Each measure is related to a defined effort for investment which build together the total invest costs of the project. In the case of installing a new biomass fired boiler, the project includes seven individual main measures. For this project, the following equipment had to be installed:

Woodchip boiler, woodchip storage, biomass scales, infrastructure for logistics, woodchip transporter, compressor, generator, automatic ash removal. The changes in the operating mode and the network were manageable by combining the gas boilers into a common system with the woodchip boilers.

## Different Equipment Mean Different Investment Costs

Equipment	Investment Costs (€)
Biomass boiler (Danstoker VP, Danmark)	1,470,455
Economiser (AB „Axis Industries“, Lithuania)	293,841
Compressor (Atlas Copco, Italy)	12,964
Generator (Lynz electric/Perkins, UK)	15,084
Woodchips storage	62,925
Metal chimney	90,978
Scales	27,337
Total costs of investment	1,973,588

## Financial Support from European Union

The EU granted **financial support** of 981,232.61 € (49.72 % of total project cost) by a Cohesion Fund from 2007–2013, to stimulate the replacement of fossil fuels by renewable biomass. A **Cohesion Fund** was established for the purpose of strengthening the economic and social cohesion of the European Union Community in the interest of **promoting sustainable development**. Assistance from the Fund has been given to actions in the areas related to sustainable development which clearly present environmental benefits, namely energy efficiency and renewable energy.

For more information  
get in contact with:

Artur Danulevic  
Salcininku silumos tinklai  
artur.danulevic@sstinklai.lt  
Tel: +370 611 53888



## 5. Renovation of the DH System in Akmenė

Akmenė Energija – Complex Renovation of District Heating System in Akmenė Region

**Akmenė District, Lithuania**

Period of the Retrofitting Project: 2000 – 2016

Technical and  
Organisational  
Description

### Project Summary

Akmenės energija – is a utility company, which is running a long-term project of renovating the complex of district heating system in Akmenė region, covering efficient heat generation, transmission and modernising the managerial processes of servicing end users of heat and hot water in the house holds, business and public buildings.

Up to now, within this project the company has implemented several renovation steps in the district heating system. The comprehensive actions, implemented for the modernization of the entire district heating system, led to a remarkable increase in the district heating energy efficiency, such as a decrease of technical losses in district heating networks, water, electricity and fuel consumption for the generation and supply of heat.

In 2011, the company received the Euroheat & Power Award for outstanding achievements in demonstrating local Energy leadership in providing clean, sustainable energy solutions to mitigate climate change.



Figure 14 Before the upgrading process



Figure 15 After the upgrading process

### Project's Characteristics

Retrofitting Types	Targets of the Retrofitting Measure	Effected Area
Technical, Economical, Organisational, Managerial	Primary Energy Savings, Efficiency Gains, Share of Renewables, Use of Residual / Surplus Heat, Economic Improvement, Displacement of Fossil Fuels	Primary Grid, Power Plants, Business Models, Heat Transfer Station, Telemetry and Remote Meter Reading



## Motivation behind the Project

The company entered into concession agreement and leased the assets from the municipal company with the aim to renovate and modernise the old soviet-type of heat generation and transmission facilities, increase efficiency, decrease CO<sub>2</sub>-emissions and create a successful business model with a modernized complex of heat generation and supply infrastructure. Therefore, the company prepared a complex project plan for the renovation of district heating assets. In the beginning, the company just aimed to renovate the inefficient boiler houses and to invest in modern and efficient gas boilers. However, while the project was already running, the technology of district heating systems evolved and the situation in the market changed. Lithuania joined the European Union and the EU financing for energy infrastructure became available. Hence, the company developed the planned measures further. The new developed plan pursues to increase the share of biomass in the fuel mix of the company, to change the pipelines with new insulated pipelines and to reduce the technical losses in the transmission. Furthermore, modern metering solutions for the users are included in the plan, as well as education measures for the community which would be able to reduce their heat demand and costs: This would also promote the idea of sustainable development.

## Key Engineering Solutions implemented between 2000 and 2016 in Naujoji Akmenė and Akmenė towns

The [order of the implemented measures was connected to their effectiveness](#). First, the measures with a high benefit and easy execution were implemented.

**2001:** A new 5.75 MW boiler house was built in the Ramučiai district. The boiler house is fully automated and is working without supervising personnel. It generates heat for the households of Ramučiai, a hospital, a sanatorium and several public administration buildings.

**2002:** Reconstruction and [automatization](#) of Stadiono's boiler house in Akmenė town. After the reconstruction and the implementation of an advanced and smart telemetry energy management, the optimum performance for the boiler house and quality of services to the users was ensured.

**2002 – 2003:** Several boilers were replaced and automated. [Centralized heat substations](#) were built for the users. With installing the hot water preparation close to the users, a reduction of heat losses was reached. And with the installation of individual heat substations the users are able to regulate the hot water supply services, save energy and enjoy essential hot water supply services in the households all year long, not only during the heating season as previously.

**2003:** Automation was introduced in Ligoninės' boiler house in Akmenė town, following the automation and remote management program of the boiler houses.

**2004:** The new "Žalgirio" boiler house was built. It is a new, central boiler house of Naujoji Akmenė town with the capacity of 16.6 MW. The boiler house is [fully automated](#), working without supervising personnel. It is fired by natural gas.

In addition, the Kruopiai and the Papilė boiler houses were reconstructed, thus enabling efficient and fuel saving heat generation even in remote settlements of Akmenė region.

**2011:** EU co-financed the reconstruction of the Žalgiris boiler-house and its adaptation for using local biomass (wood waste). The project had its environmental effect through the decrease of CO<sub>2</sub>-emissions and district heating tariff right after its completion, i.e. for the heating season starting October 2011.

**2000 – 2011:** The company changed 89% of the pipelines in the town with new cased underground pipelines. This increases the reliability of the heating networks and eliminates the risk of accidents and break-downs. It minimizes technical losses down to 8.8% and increases the efficiency of the heat supply through the reduction of fuel consumption for the generation of heat.



Figure 16 Old exposed pipelines



Figure 17 New cased underground pipelines

In 2006, JSC “Akmenės energija” received a 50% co-financing from the EU Structural funds because the project goals corresponded with the state priorities for co-financing of the projects, i.e. to increase the efficiency, to decrease technical losses, to save fuel, to protect the nature, to use modern technologies for energy generation, transmission and supply, as well as to set the basis for future reliably and cost effective utility services, thus increasing the quality of living for the communities and attractiveness of the region both for the business and for the society.

**2016:** A 2.5 MW biomass boiler house with condensing economizer was built in Venta (using EU support schemes). The gas boiler house in Ligoninės was modernized with a new efficient boiler house including new boilers. Furthermore, the boilers of Kruopiai’s town were changed.

For more information  
get in contact with:

Raminta Barauskiene  
E energija, Administrative Director  
r.barauskiene@e-energija.lt



Ieva Norkiene  
Akmenės energija, Ekonomist  
i.norkiene@e-energija.lt



## 6. Green Energy Park Livno

Cogeneration Plant and District Heating System on Biomass of City Livno

Livno, Bosnia and Herzegovina

Period of the Retrofitting Project: 2012 – 2016

Economical  
Description

### Project Summary

The project “Green Energy Park Livno” includes the development, design and implementation of renewable energies. It aims to contribute to a more secure, competitive and sustainable energy production in the Municipality of Livno through targeted support of renewable energies in form of wood chips and solar. The project increases the use of renewable energy sources, specifically for heating public buildings, business buildings and individual houses, as well as renewable electricity production.

Many benefits have been achieved by implementing the retrofitting measures from 2012 to 2016 such as reconstruction of 2,600 m of pipe network, upgrading of the boiler room, installation of additional biomass boilers, extension of the piping network. In 2013, photovoltaic panels (844 m<sup>2</sup>/79 kW<sub>p</sub>) were also installed.



Figure 18 Before the upgrading process



Figure 19 After the upgrading process

### Project's Characteristics

Retrofitting Types	Targets of the Retrofitting Measure	Effected Areas
Technical, Economical	Primary Energy Savings, Efficiency Gains, Share of Renewables, Economic Improvement, Displacement of Fossil Fuels	Primary Grid, Secondary Grid, Power Plants, Business Models

### Motivation behind the Project

The previous district heating system (based on fuel oil) was characterized by high consumption of fossil fuels and electricity, inefficient boilers, low heating comfort, low energy efficiency and high environmental pollution.

The following objectives were identified to improve the performance of the previous district heating:

1. Improve heating comfort levels in public buildings, business buildings and private households in the city by using available biomass (wood chips) from local wood industries and forest residuals;
2. Stimulate the national market for efficient household heating, industrial cogeneration and electricity production for renewables;
3. To provide sustainable profitable solution as model for raise regional capacity in the biomass sector, ensuring sustainability and further replication;
4. Increase awareness and acceptance, creation of jobs, promote the benefits of renewable energy and ensure the visibility of project results.

### Different Measures mean Different Investment Cost

For upgrading projects, the financial aspect is one of the critical values. Within the project's period, multiple measures were implemented to address the identified goals. These individual measures lead to individual investment costs and individual revenues. For this project, the financing was divided into five parts.

Item	Details	Estimated Costs (€)	Estimated Revenues (€/a)
Thermal-energy equipment with biomass supply system		1,405,000	
Pipe network and connection equipment		166,170	
ORC system	Heat 14,336 MWh/a Electricity 9,454 MWh/a	2,150,000	1,565,697
Photovoltaic panels	Electricity 92 MWh/a	178,950	34,620
Construction		178,950	
Operation costs (salaries, maintenance, fuel/biomass)		492,800	
Total investment and revenues without operation costs		4,079,070 (30% owner's equity, 70% bank loan)	1,600,318

## The Project's Cashflow presents an Economic Benefit after Year Seven

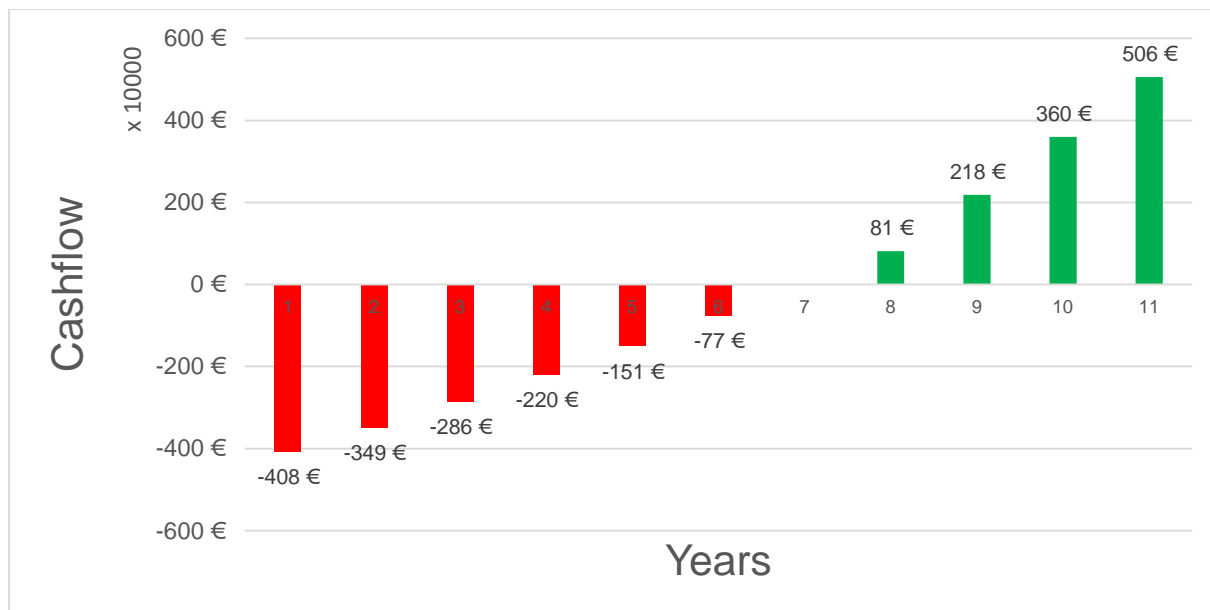

Figure 20 Expected project's cashflow in eleven years, based on: [www.unece.org](http://www.unece.org)

### Project's Lessons Learned

It is **essential to have a long-term view** when considering DH system modernisation, as it is associated to high investment which are resulting in a long payback period. It is strongly recommended that financial decisions should not only be made on the basis of payback time, but also on the systems life cycle costs.

**The economic analysis of DH system modernisation should be part of a long-term plan for DH system operation and development.** The analysis should define the scope of modernisation broken down in several steps which should be the basis for investment and loan negotiations with potential investors and banks.

Long term planning of the heat supply should be based on an evaluation of local conditions and all possible solutions (available fuels, technologies and heat sources, and transmission and distribution networks). **Existing and expected changes of the heat demand** need to be considered as well as **the life cycle of single components** and **available financial resources**.

For more Information follow the references:

[Green Energy Park Livno, Renewable Energy, UNECE Investments in sustainable renewable energy generation in 2017](#)

[Project Identification Form – PIF, Energy Park Livno, Energy Globe Award 2013](#)

Or get in contact with:

Vanja Curin  
Dvokut/ESCO EE, Board Member  
Tel: +387 33 447 881  
vanjacurin@gmail.com





## 7. Replacement of Fossil Fuels in the DH Sector of Lithuania

Regulatory Instruments and Investment Subsidies applied in the DH Sector of Lithuania to Stimulate Replacement of Fossil Fuels by Renewable Biomass

Lithuania



Start of Supporting Upgrading Projects: 2000

### Project Summary

Renewable energy sources (RES) consumption has been continuously growing in Lithuania. During the period of 2000–2017, the use of RES for heat production in the district heating sector increased from 2 % up to 68.7 %. Wood chips are the commonly used RES for heat production. The lower prices were one of the main reasons which motivated district heating companies, to switch from natural gas to biomass. At the same time, subsidies, soft loans, EU Structural Funds for 2007–2013 and 2014-2020 some fiscal measures, which are currently available for RES promotion, also have some impact on the increasing consumption of RES.

After LT made the political decision to join the EU, the implementation of EU directives to national legislation started. The replacement of fossil fuels by renewable energies was the key trend in the EU energy policy. There were also additional (even regional) incentives to support the transition from natural gas to biomass.

Furthermore, the development of RES in Lithuania is part of a sustainable policy. The use of local biomass in the district heating companies is producing high added value: cheaper heat for consumers, money for the purchase of fuel remains in Lithuania, new jobs are being created, and clean environment.

### Project's Characteristics

Retrofitting Types	Targets of the Retrofitting Measure	Effected Areas
Economical, Organisational	Primary Energy Savings, Efficiency Gains, Share of Renewables, Use of Residual / Surplus Heat, Economic Improvement, Displacement of Fossil Fuels	Power Plants

### Motivation behind the Project

Several objectives stimulated the replacement of fossil fuels by biomass. One of them, was the limitation, which was set by EU, to use high sulphur content fuels (above 1 %). Lithuanian DH enterprises which had no access to the natural gas network first, started to replace heavy fuel oil firing boilers to biomass boilers. The decision to join EU was made in 1995, and in 1999 Lithuania received a formal invitation to begin membership negotiations. The second objective was to get more indecency by using regional energy sources instead of imported fossil fuels. From 2007 this became a key target in all Energy Strategy versions. Another factor was the national regulation of DH prices by using incentive instruments, which was introduced from 2003 after the Heat Law was adopted by the LTU Parliament. The last decisive point was the first financial package of the EU support funds (2004-2007), which was especially allocated to the replacement of fossil fuels by renewables.

For this kind of projects, and this form of comprehensive projects, [the support of key actors in all involved sectors](#) is indispensable.

### Key Actors and Supporters

Political Sector	Economic Sector	Industrial Sector
Ministry of Energy of the Republic of Lithuania	Energy experts	Lithuanian district heating companies
Ministry of Economy of the Republic of Lithuania	Consultants	Independent heat producers
Ministry of Finance of the Republic of Lithuania		
Lithuanian Business Support Agency		
National Commission for Energy Control and Prices		
municipalities administration		

### Minister of Energy, Mr. Žygimantas Vaičiūnas

“The development of renewable resources is one of the main objectives of energy policy in order to reduce dependence on imported fuels. The goals set have helped Lithuania to reduce its dependence significantly in recent years. Now we are continuing to reduce dependence.” (22<sup>nd</sup> of March 2017)

The participation of the EU and the use of financial support from EU funds, entails a high organisational effort. Different aspects need to be noted. Within this project, especially nine main administering spheres were considered.

#### The Main Spheres of Activity in Administering National and EU Funding

- Announcing calls to submit applications for funding
- Checking and assessing applications
- Concluding funding agreements
- Supervising and controlling implemented projects
- Checking and assessing payment claims
- Collecting information on granted funding, entering data into the information system
- Providing the information necessary for applicants to prepare and submit applications, organizing information and training workshops as well as other events
- Publicizing granted assistance
- Performing other assigned functions

#### Operating Support Schemes for Biomass Development in Lithuania

1. Incentive pricing element: when natural gas costs are included in the heat prices, the enterprises use cheaper biomass. The cost savings are used for repayment of credits during single regulatory period.
2. Double rate applied in setting of regulatory profit to the value of assets, which is necessary for the use of renewable energy sources (including biomass).
3. Investment subsidies up to 50 % were available for the projects introducing renewable energy sources.
4. Bio-cogeneration power plants received investment support and the purchase of electricity at a higher tariff than the market was guaranteed;
5. The National Commission for Energy Control and Prices set additional profit margin due to investments made;
6. Competition between heat suppliers and independent heat producers - independent heat producers have been enabled to include natural gas price in the heat tariff despite the use of biomass in the fuel mixture.
7. Financial support to biomass producers and suppliers for the acquisition of equipment. New projects of cogeneration plants are recognized as projects of state importance.

For more information  
get in contact with:

Audronė Nakrošienė  
Lithuanian District Heating Association, Training Programme  
Manager  
audronenakrosiene@gmail.com

Valdas Lukoševičius  
Lithuanian District Heating Association, President  
valdas.lukosevicius@lsta.lt

## 8. Integration of Solar Thermal Energy in an Existing DH System

Berlin, Germany

Organisational Description

Year of the Retrofitting Project: 2018

### Project Summary

The energy utility Vattenfall is one of the largest district heating providers in Germany, owning numerous power generation plants as well as combined heat and power (CHP) plants. Vattenfall has several CHP plants in Berlin and Hamburg, together with a distribution network of around 2,650 km in length.

In 2018, the energy utility Vattenfall Wärme Berlin AG upgraded its DH system in Berlin-Köpenick with a solar thermal plant. The plant was planned and constructed by the Danish turnkey supplier of entire solar heating systems Arcon Sunmark, which now realised their first plant in Germany. After only 10 weeks of construction the SDH plant was taken into operation in May 2018 with a minimum expected life time of 25 years. The plant is placed right in the area of Köpenick, surrounded by residential buildings and businesses. The collectors feed the solar heat into the return pipe of the district heating system throughout the year, using a heat exchanger without an additional thermal energy storage. The plant's expected annual heat production is 440 MWh. Within the first seven month of operation and the hot summer 2018 in Germany approximately 500MWh were already reached.



Figure 21 Before the retrofitting measure  
(source: [Vattenfall Deutschland](#))



Figure 22 After the retrofitting measure  
(source: [Vattenfall Deutschland](#))

### Project's Characteristics

Retrofitting Type	Targets of the Retrofitting Measure	Effected Areas
Technical	Share of Renewables, Economic Improvement, Displacement of Fossil Fuels	Primary Grid, Power Plant

### Motivation behind the Project

The restructuring of Vattenfall's thermal business in the Germany's capital city is progressing steadily. In Berlin by 2030 at the latest, the coal is to be eliminated. Gunther Müller, Berliner Vattenfall Heat CEO, explains the significance of the project: "The primary goal of Vattenfall is to **be CO<sub>2</sub>-free within a single generation**. For our business in Berlin, this means **generating and supplying heat without emitting greenhouse gases**. To do this, we are transforming our entire portfolio of facilities into sustainable energy sources, becoming **more digital and decentralized**. The lignite withdrawal in May 2017 was a giant step on this path - now comes the hard coal. With the feasibility study, Vattenfall and the State of Berlin are working together to develop the timetable so that by 2030 the last coal-fired plant can go offline."

Also other projects, such as the project "Urbane Wärmewende" (urban heat energy transition) support Berlin's ambition to pursue an urban heat supply that is **environmentally and socially compatible**, and smartly interconnected with other infrastructures and resilient. These initiatives and targets contributed to Vattenfall's decision for upgrading its DH system in Berlin-Köpenick with solar thermal collectors, hence **increasing the share of renewable energies** and reducing the need for combustion fuels.

### The Way from the Idea to the first feed-in MWh

Vattenfall wanted to find the best solution to cope with the challenges of a CO<sub>2</sub>-free future. Therefore in 2014, Vattenfall's employees were asked to **develop ideas and options for transforming** the heat-generation systems. The most reasonable idea was to **upgrade the cogeneration plant** with additional solar thermal plants. Then, this idea was well discussed within the company and it was decided to initiate a first **pilot project**.

Fortunately, at the same time Vattenfall's island networks were investigated to **improve their primary energy factor**. In this context, unused area of the company were investigated as well. Hence, it was possible to name a precise area and district heating network for the solar thermal pilot project.

The next step was the feasibility study. For this project two feasibility studies were carried out. The first shows the **feasibility of the technical implementation** of the solar thermal plant in the existing network, but pointed out unprofitable economic characteristics. Only with a second more detailed study and a precise offer from the Danish solar plant supplier Arcon Sunmark, **the economic feasibility** was achieved.

With these results, the pilot project was further elaborated, subsidies were requested from the German KfW Group and internal approvals were enquired. Compared to other project procedure steps, this took very much time. After the project was approved, the period between the groundbreaking ceremony and the placing into operation was **just ten weeks**.

### Available Land in Urban Region

The implementation of solar thermal projects in urban region often leads to discussions about the **use of available land** for living space or for sustainable energy generation. Especially, if the municipal utility is not owner of the available land, the implementation of these projects is challenging. Because of the high standard ground value in densely populated regions, a good approach would be the **cooperation with landowners** of areas which are not suitable for living space. These areas are for example sealed disposal sites, rain-seepage areas or sewage irrigation fields.



## Dimensions and Benefit

The general benefit, of plants with this dimensions, is the feasibility to integrate the **plant easily in already existing networks**. In less than three month, after the order is placed, the plant can be put into operation. The project shows an **effective solution to optimize the district heating system** with a small effort of time.

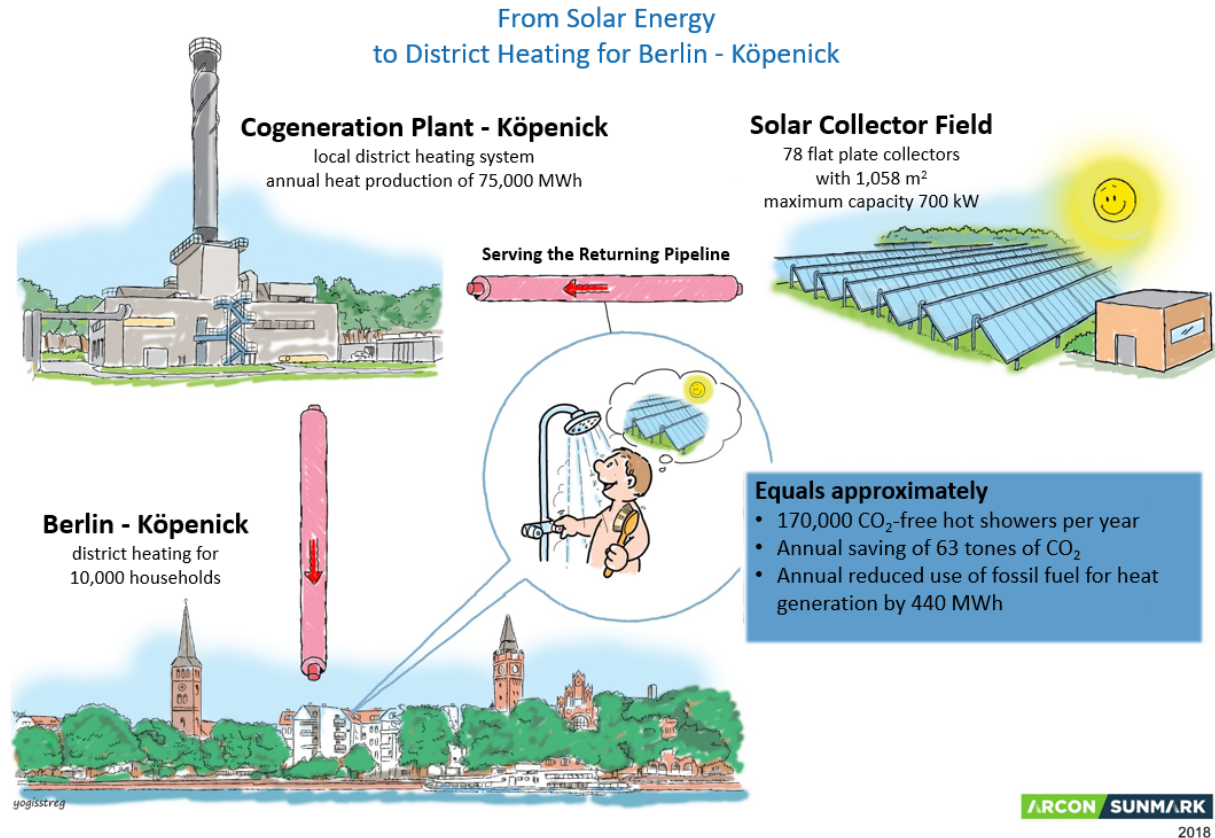

Figure 23 Illustration of the district heating system in Berlin Köpenick after the upgrading project

For more information follow the references:

[News blog Vattenfall](#)

[Urban solar heating system in Berlin](#)

or get in contact with:

Edgar Scheider  
Vattenfall, Responsible Project Manager  
edgar.scheider@vattenfall.de

Christian Stadler  
Arcon-Sunmark GmbH, Managing Director  
chs@arconsolar.com

Sebastian Grimm  
AGFW Projekt GmbH  
s.grimm@agfw.de

## 9. Energy Renovation with Focus on Low-Temperature DH in Albertslund

Energy Renovation of District Heating System in Albertslund Syd with Focus on Low-Temperature District Heating

Albertslund, Denmark

Managerial  
Description

Period of the Retrofitting Project: 2013 – 2015

### Project Summary

The community of Albertslund takes environmental problems seriously and wants to reduce CO<sub>2</sub>-emissions towards a CO<sub>2</sub> neutral energy consumption. In 2008, Albertslund was the first municipality in Denmark that became 100% environmentally certified.

The retrofitting measures were applied to Albertslund Syd in Albertslund Municipality, where problems with high energy consumption, bad indoor climate and bad cooling of the supply flow were identified in the buildings. The implemented measures involved the renovation of the district heating network connected to the buildings, as well as the buildings' envelopes and installations. The main benefits reached by the retrofitting are related to the reduction of the heat loss from the buildings as well as the reduction of the district heating losses. At the same time the flexibility of the system has been increased, leading to a system that can better include sustainable energy solutions.



Figure 24 During the upgrading process



Figure 25 After the upgrading process

### Project's Characteristics

Retrofitting Types	Targets of the Retrofitting Measure	Effected Areas
Technical, Economical, Managerial	Primary Energy Savings, Efficiency Gains, Share of Renewables, Economic Improvement	Secondary Grid, Heat Transfer Station

### Motivation behind the Project

The upgraded area is a residential area composed by about 1,500 houses and apartments with different kind of dwellings, such as terraced houses, apartment blocks and single family houses as well as schools and public buildings. The area was built between 1963 and 1968 and the buildings are built with concrete elements solutions. **The main motivation behind the project was to improve the unsanitary old buildings, decrease the energy consumption and enable the use of low temperature low district heating.** Therefore, an upgrading process including different retrofitting measures was developed and implemented.

### Implemented Measures

Supplier-Side	Distribution-Side	Consumer-Side
Continuously monitoring of the performance	Continuously monitoring of the performance	Continuously monitoring of the performance
	Renovating the network by installing pre-insulated twin pipes	Renovating the envelope of the buildings
		Installation of space heating systems
		Installation of new ventilation systems

Managerial aspects are always an important factor for the success of projects. An efficient project management is the backbone of an efficient project running.

### Managerial Point of View for Albertslund

In the managerial aspect of the retrofitting project, different steps were considered from the beginning of the process, to **understand the problems and then to find the optimal solution.** Firstly, a mapping process was done to identify the areas in Albertslund municipality that had the main problems related to energy consumption and the bad conditions of the district heating network. Secondly, the possible solutions and improvements were investigated that could be implemented for the district heating network, as well as for the buildings, in order to **reach the requirements for both the users and the supplier side.** Once the retrofitting measures were implemented, it was decided to monitor the results by checking some parameters that could help to understand the performance of the system, such as heat consumption and supply/return temperature.

### Stakeholders and Stakeholder's Co-ordination

For an efficient project management with projects including more than one stakeholder, it is important to ensure a smooth co-ordination and co-operation between the stakeholders. Within this project, two stakeholders were identified, which are directly affected by the project and therefore important for the project's process.

## 1. Suppliers

The suppliers' side was mainly represented by the district heating utility Albertslund forsyning, but also by the service suppliers for water, electricity, and communication. The overall aim with regard to district heating was to improve the efficiency and sustainability of heat supply, both by reducing heat losses and by utilizing waste heat sources.

The discussion on suitable technical improvement solutions required careful coordination between all service suppliers as the available space of the underground-trenches is limited. This was managed by COWI's project manager via a process of meetings and interactive design works.

## 2. Consumers

The consumers' side includes the housing association as well as the residents of the dwellings. The Housing Association (and residents) wanted the dwellings to be renovated to a good overall standard. This should increase the liveability of the dwellings, improve the settlement and attract new families to the area.

The cooperation with the residents was generally very good, since they had an active part in planning the project and as they were well informed by the Housing Association. The Housing Association managed the interaction via regular meetings and a residents committee, and also updated the residents regularly about the progress. During the external renovation, the residents could stay in their houses, whilst for the inner renovation, the residents had to leave their flats.

### Project's Lessons Learned

The retrofitting process in the Albertslund Syd area led to good results in terms of reducing the energy consumption of the buildings and the heat losses in the distribution network, which were mainly achieved with the renovation of the buildings and the adoption of a new piping system.

It was decided to measure the energy consumption in each single apartment/dwelling and to show the results to the users. This led to higher awareness of the users about how they use the heating system and how they can optimise the energy consumption, while having a good indoor climate. The results showed, how important this user-education is. Due to the transition from high-temperature radiators to low-temperature space heating, a transition in the user's heating-behaviour was needed as well.

Hence, this project was part of a larger building renovation project, the dialogue and information flow were all managed by the Housing Association. This was essential to the smooth running of the district heating installation. Due to the regular updates from the Housing Association, the residents were generally well informed and the resident's acceptance and willingness for cooperation was very good.

For more information follow the reference:

Hans-Herik Høg and Theodor Møller Moos. (2015). Switching to 4th-Generation District Heating in Albertslund - DK. Hot Cool, Journal no. 4/2016

Or get in contact with: Theodor Møller Moss  
COWI, Chief Project Manager  
TMM@cowi.com



## 10. Interconnection of Two Separated DH Networks in Italy

Increase Return on Invested Capital with Large Interconnection Project of Separate District Heating Networks

### Anonymous Project in Northern Italy

Period of the Retrofitting Project: 2015 – 2017

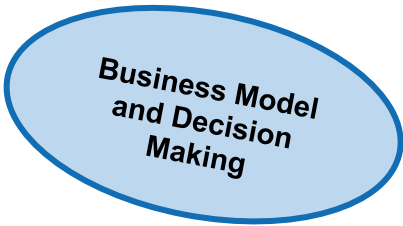

#### Project Summary

A leading Italian utility made a large investment on the interconnection between two formerly separated networks, in order to diversify and improve the fuel mix and to increase the heat use from a Waste-to-Energy plant (WTE) instead of a combined heat and power plant (CHP). The use of advanced optimisation tools allowed to perform an innovative analysis to identify the most attractive development scenarios.

The utility has a series of isolated systems in Northern Italy. Two of them, both serving mainly residential customers in highly density areas, were fuelled by two separated generation plants (see below). In the original configuration, the plant serving area 1 was a large gas-fuelled CHP plant, including several endothermic engines (CHP), boilers, one large heat pump and a storage system. Area 2 was served by a large Waste to Energy facility that treats urban and special waste.

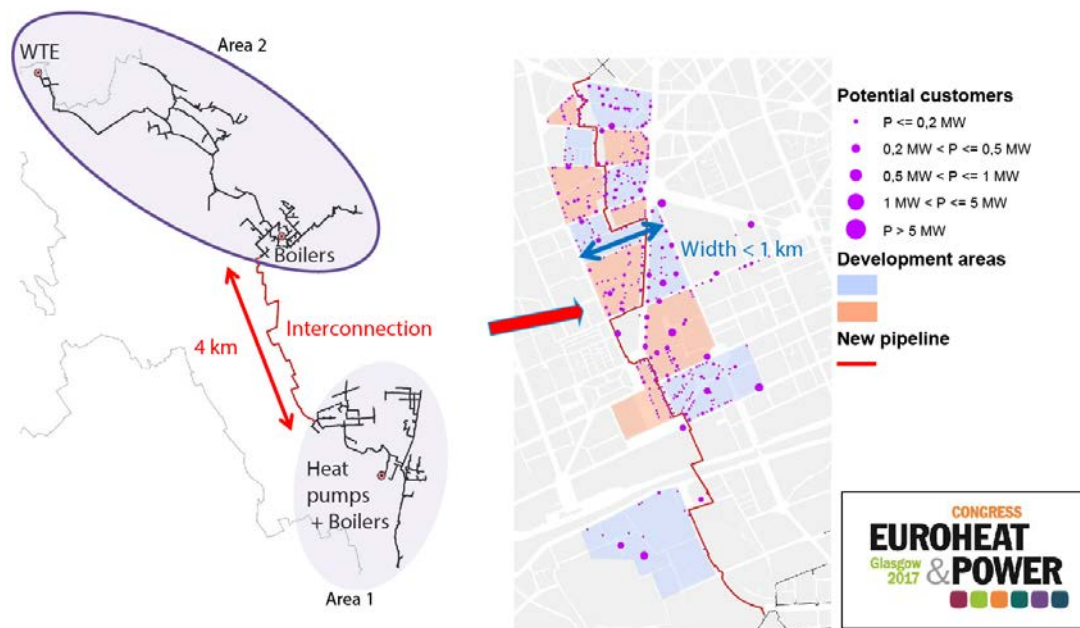

Figure 26 Plan of the separated district heating networks, source: [www.4dh.eu](http://www.4dh.eu)

#### Project's Characteristics

Retrofitting Types	Targets of the Retrofitting Measure	Effected Areas
Technical, Economical	Use of Residual / Surplus Heat, Economic Improvement, Optimized Network Development Design	Primary Grid, Business Models



### Motivation behind the Project

The key problem arising in recent times, was an increasingly deterioration of the power plant performance in network 1, that resulted in longer maintenance times and low reliability (when switched on, engines may not start operating in a timely manner). To address this issue, two possible options were discussed.

Option 1: As a result, the “conservative” option for the utility was to revamp the plant, with a very large investment.

Option 2: An alternative scenario was analysed and put in place: to design a large network backbone and interconnect the two areas and decrease usage of fossil fuels, thanks to a higher utilization of the cheaper heat from the WTE unit.

Finally, the decision was made for option two. Several positive aspects, from different points of view, showed a lot of benefits. The interconnection led to a **higher usage of the WTE** which addresses **environmental issues** by shifting from gas-fuel fired plants to waste heat. Furthermore, the interconnection expanded the network and allows the connection of **more consumers** to the district heating system. This has an impact of the economy of the heat supply as the connection of new customers means **more profit**.

### Effect on the Utility's Business Model

Once, the backbone interconnection was designed, it was necessary to investigate how to use the new available capacity. This scenario was analysed with the support of Optit's tool. Such decisions imply a continuous collaboration between marketing/sales and engineering. For a successful implementation, it was important for the decision-making process, to take marketing/sales and engineering aspects into account. New areas of the city could have access to DH, which requires a higher generation capacity.

### Best Practice Tools for Best Practice Projects

The Upgrade DH project identified and examined best practice examples on projects as well as on instruments and tools. One of these tools is the OptitDHN or even “Optit's solution for district heating network's development. This tool which was used in this project to support the decision making process and to investigate the impact of the network-interconnection.

To get more and detailed information about this tool or other **successfully applied tools** and instruments for upgrading projects, visit: [www.upgrade-dh.eu](http://www.upgrade-dh.eu).

## Lessons Learned and Special Advice

Effective decision making needs to be based on strong analytic which is very valuable to large utilities that need to make several high investment decisions.

In fact, the tool is helpful to support both investment (strategic) decisions and commercial (tactical) planning, given the high level of granularity that can be managed with the tool.

The fact that such sophisticated tools (that includes a full thermal-hydraulic model) could be used by non-engineering staff was another advantage.

Due to the innovative nature of the project, the solution and its application to the specific case was presented in several international conferences, including:

- 4DH conference in Aalborg, in 2016
- Euro Heat & Power conference in Gotheborg, in 2017
- Digital Heat in Bruxelles, in 2018

It is planned that the tool is increasingly used to assess and to refine alternative economic and tariff scenarios, and also to evaluate the soundness of effective implementation allowing planned versus execution assessments.

It is obvious that the investment in a specific software only justifies itself if sufficient scale (and complexity) is available, yet the capability to acquire this service as “consulting service” can fit the case of smaller operators (or bigger ones, with spot needs).

For more information follow the references:

[Decision support system for district heating net development optimization](#)

Bordin, A. Gordini, D. Vigo. - An optimization approach for district heating strategic network design. European Journal of Operational Research, 252(1):296– 307, 2016

Or get in contact with:

Matteo Pozzi  
OPTIT srl – Optimal Solution  
matteo.pozzi@optit.net  
Tel: +39 335 7160557

